

Test: Primary 4 - Term 4 Science (Rosyth)

Points: 77 points

Name: _____

Score: _____

Date: _____

Signature: _____

Select multiple choice answers with a cross or tick:

Only select one answer

Can select multiple answers

Question 1 of 63

Primary 4 Science (Term 4) 2 pts

Booklet A (28 x 2 marks)

For each question from 1 to 28, four options are given. One of them is the correct answer.

The table below shows how some living things can be grouped.

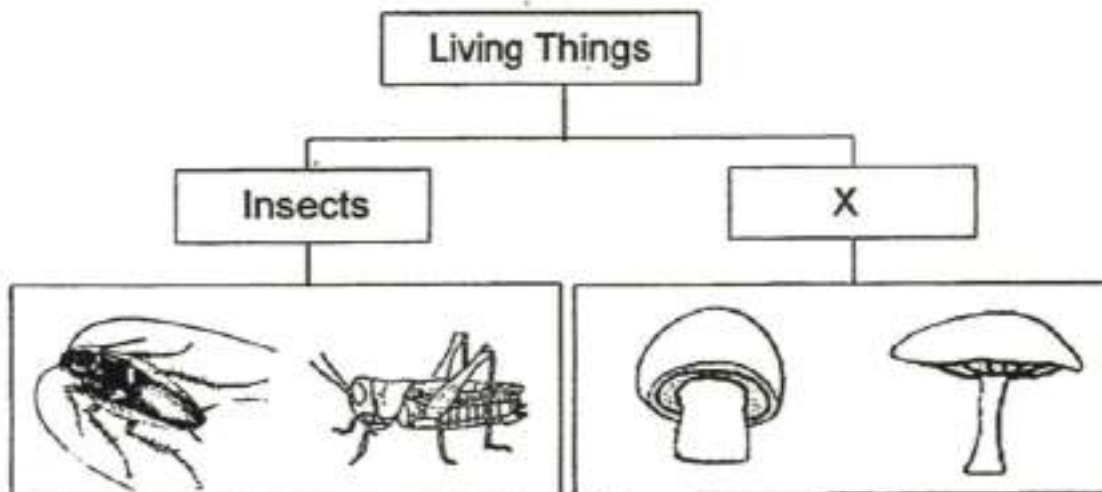

Which one of the following is the most suitable heading for group X?

- A) fish
- B) fungi
- C) bacteria
- D) mammals

The diagram below shows the order of some organs in a human digestive system.



What is the missing part in the box above?

-
- A) anus
 - B) gullet
 - C) mouth
 - D) small intestine

Study the classification chart below.

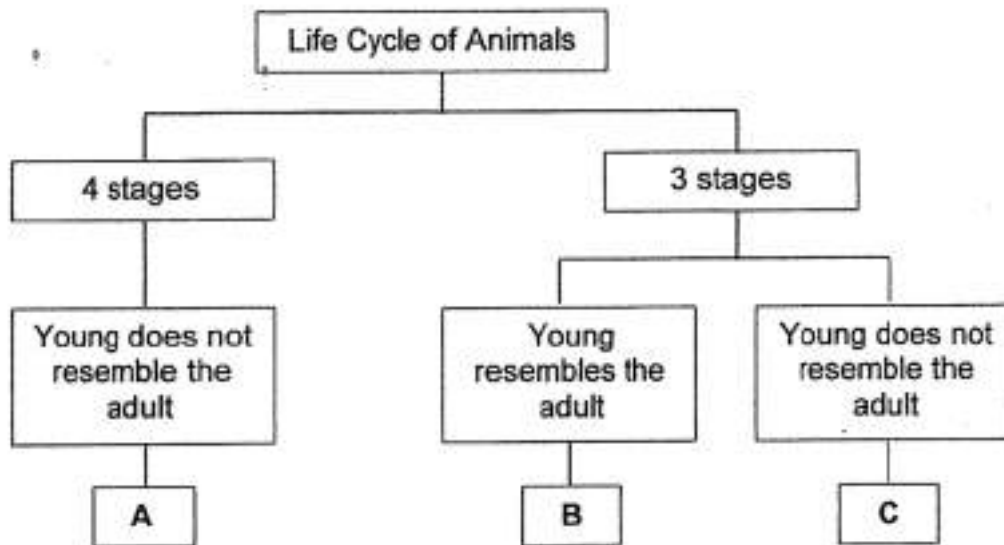

Which one of the following represents A, B and C?

| | A | B | C |
|-----|-----------|-----------|-----------|
| (1) | chicken | butterfly | frog |
| (2) | butterfly | chicken | frog |
| (3) | butterfly | frog | chicken |
| (4) | frog | chicken | butterfly |

- A) 1
- B) 2
- C) 3
- D) 4

The diagram shows a painting hanging on a wall.

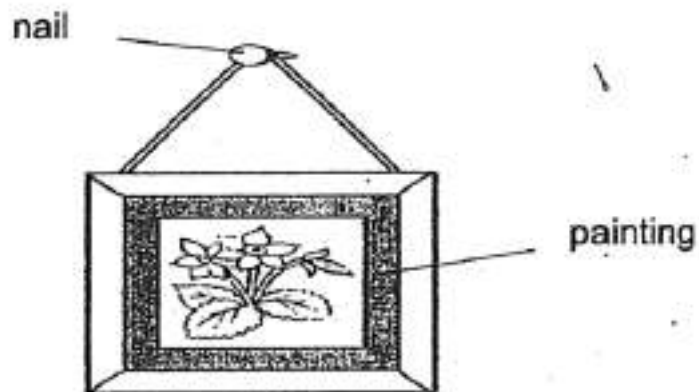

Iron is used to make the nail because iron is _____.

- A) shiny
- B) strong
- C) flexible
- D) waterproof

An object X was attracted to a magnet, as shown in the figure below.

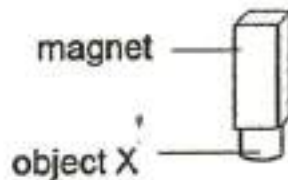

Object X is made of _____.

- A) iron
- B) wood
- C) rubber
- D) plastic

Question 6 of 63

Primary 4 Science (Term 4)

2 pts

Matter is anything that has mass and occupies space.
Which one of the following is not matter?

- A) air
- B) light
- C) sand
- D) water

Which of the following shows how a person can see the object under the light?

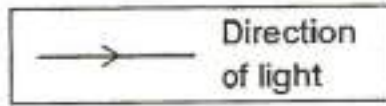

A)

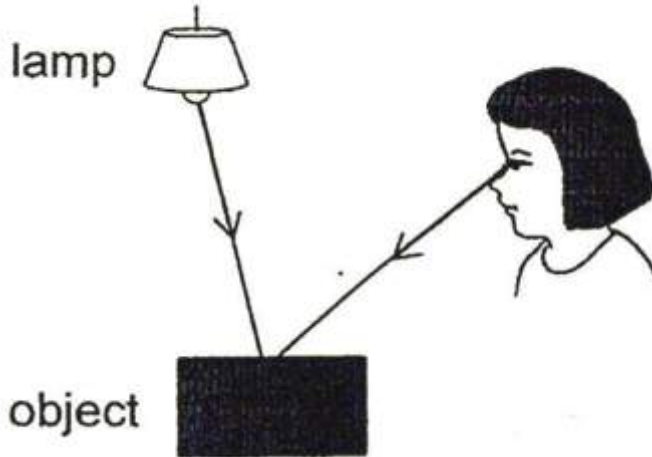

B)

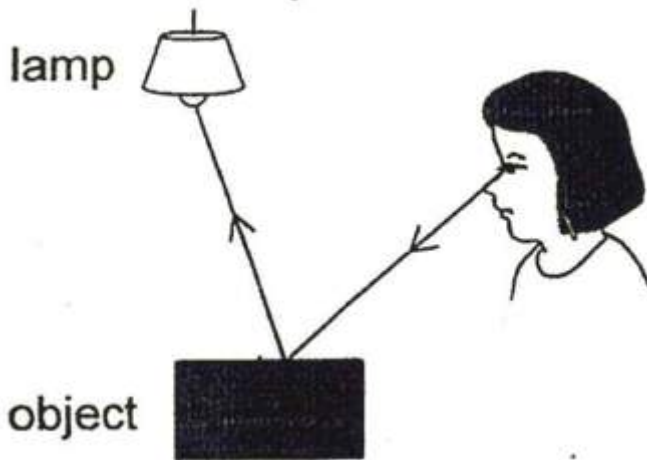

C)

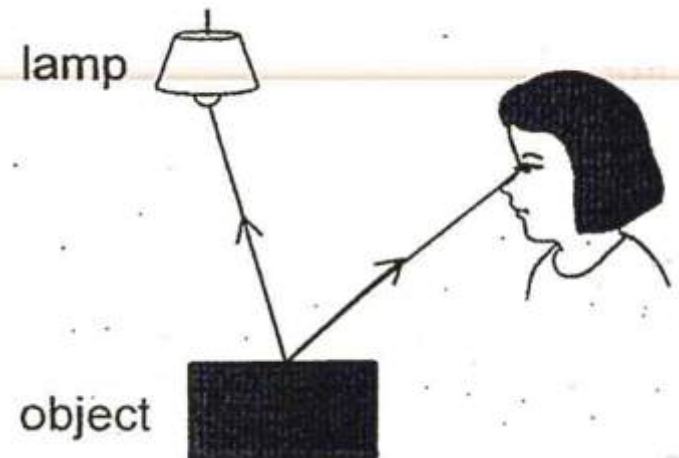

D)

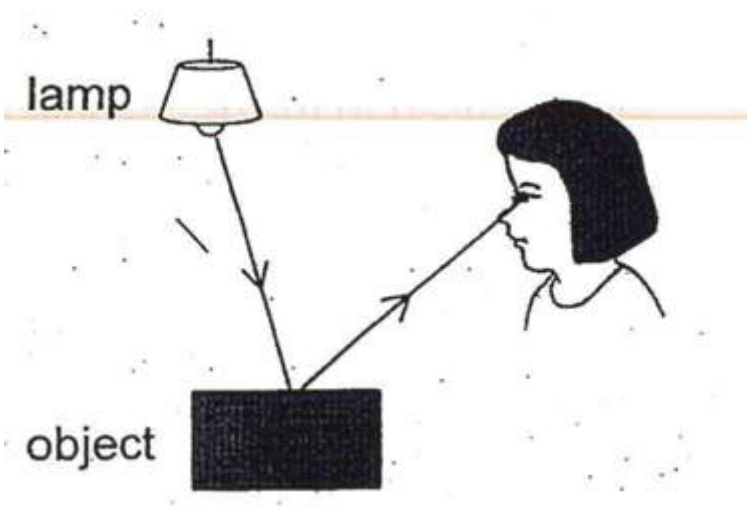

In which one of the following will the two magnets move towards each other? \$

A)



B)

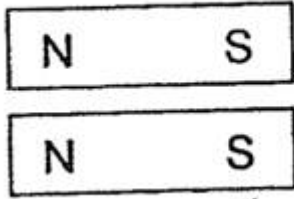

C)

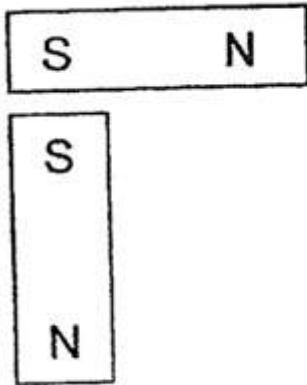

D)

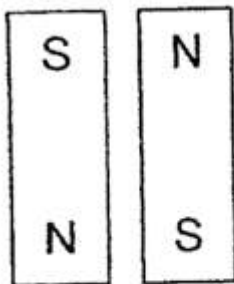

Liyana wants to measure the temperature of hot water in a beaker. Which one of the following diagrams shows the correct position of the thermometer when taking the temperature reading?

A)

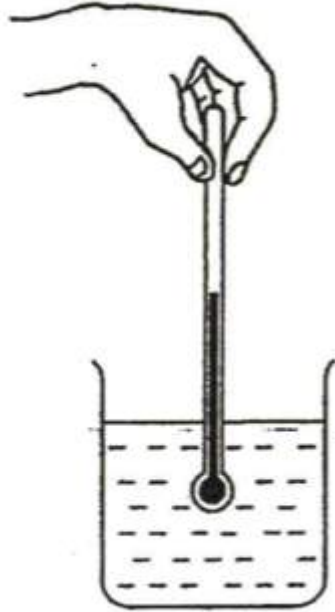

B)

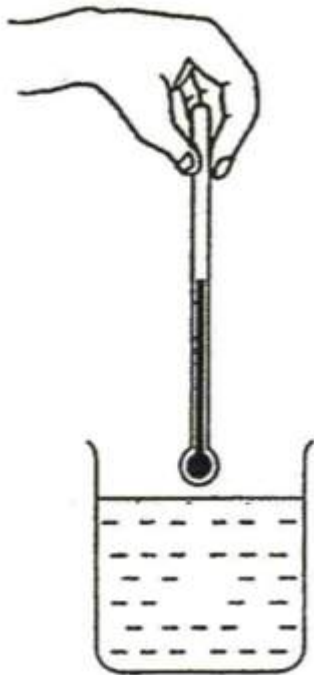

C)

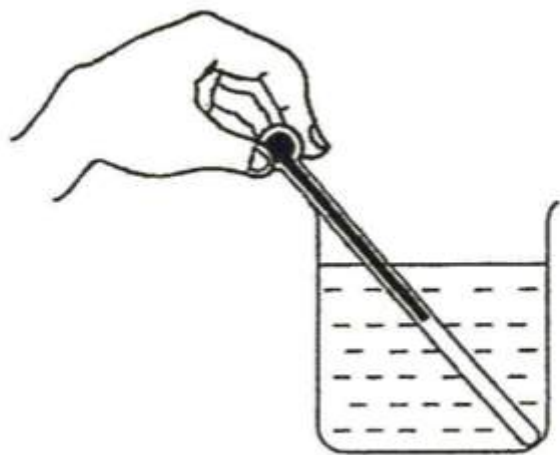

D)

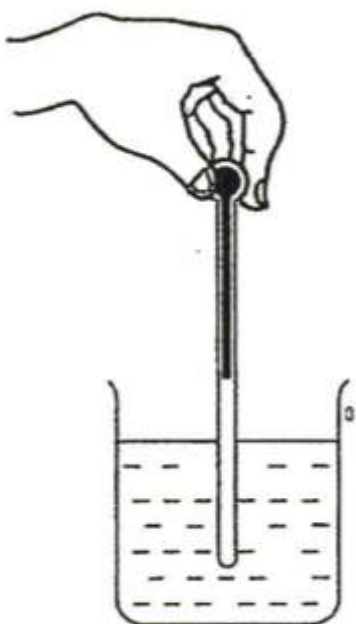

Akmal boiled some water in the pot shown below.



He is able to hold the pot of boiling water using the plastic handles.

This is because plastic is a _____

- A) light material
- B) flexible material
- C) poor conductor of heat
- D) good conductor of heat

Grace put Animal X, in a tank with some water, leaves and some flies. She covered the tank with some wire mesh to prevent the flies from flying away. She placed a banana for the flies to feed on.

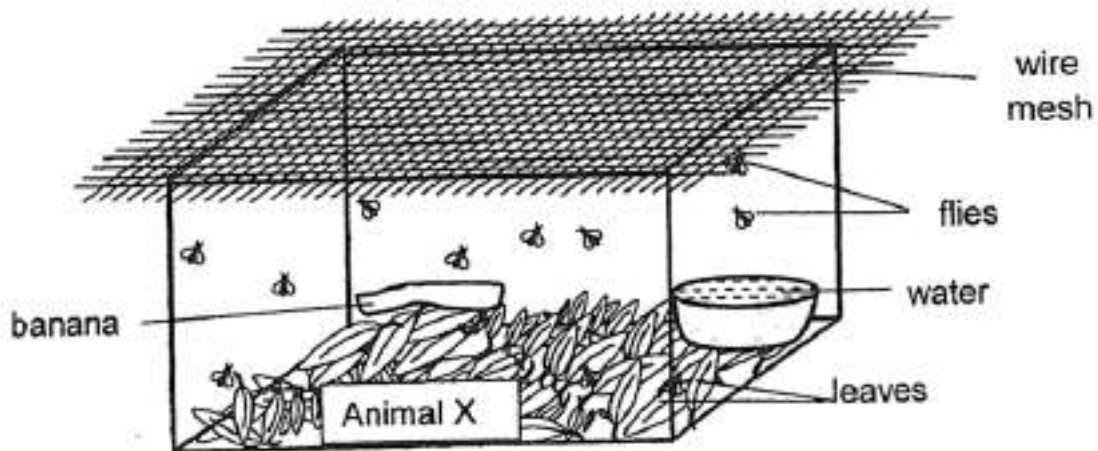

She recorded the amount of leaves and the number of flies left in the tank for the next 6 hours as shown in the table below.

| | Amount of leaves (in grams) | Number of flies |
|---------------|-----------------------------|-----------------|
| Start | 80 | 12 |
| After 2 hours | 65 | 9 |
| After 4 hours | 40 | 7 |
| After 6 hours | 26 | 4 |

What can you conclude about the eating habit of Animal X?

- A) It eats flies only
- B) It eats leaves only
- C) It eats both flies and leaves
- D) It does not eat both flies and leaves

Study the flowchart below.

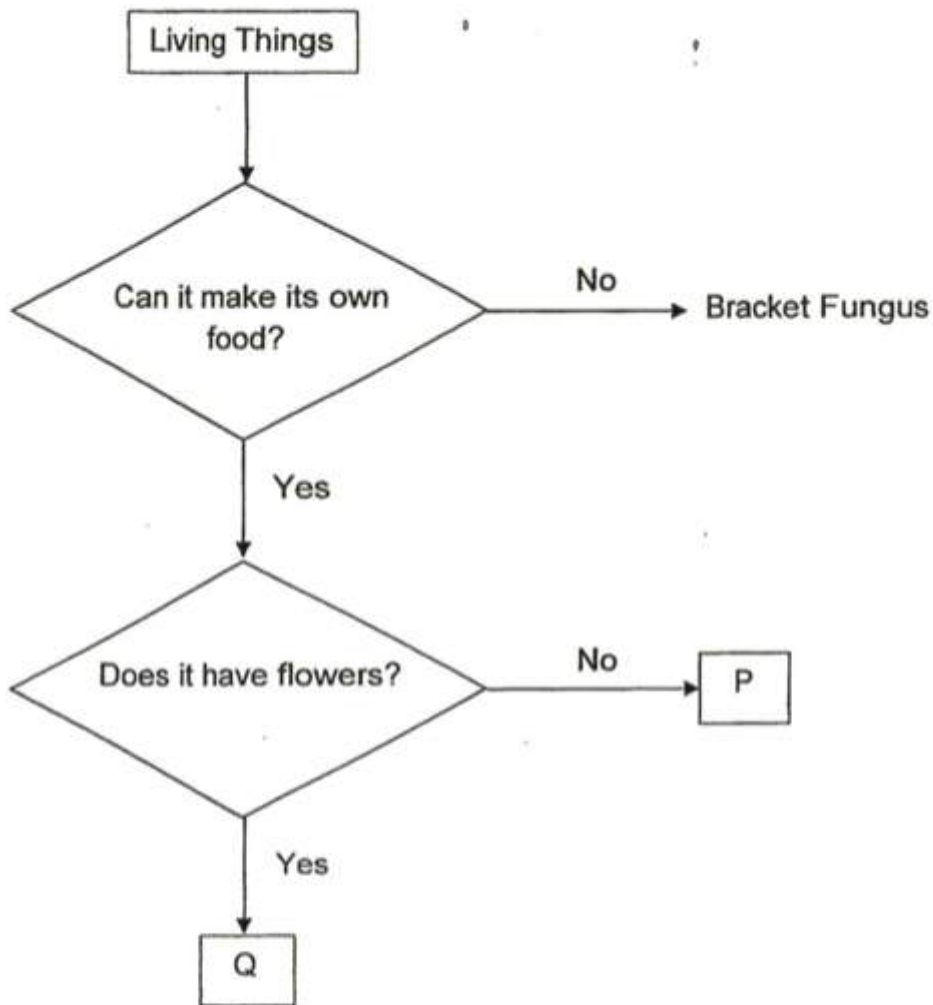

Which of the following statement best describes P and Q?

| | P | Q |
|-----|-----------------------------|-------------------------|
| (1) | P is not a plant. | Q is a plant. |
| (2) | P bears fruit. | Q does not bear fruit. |
| (3) | P does not need sunlight. | Q needs sunlight. |
| (4) | P is a non-flowering plant. | Q is a flowering plant. |

- A) 1
- B) 2
- C) 3
- D) 4

Which one of the statements below best describes the human body?

- A)** It is made up of one organ system that carries out a single function
- B)** It is made up of one organ system that carries out different functions
- C)** It is made up of many organ systems that carry out different functions
- D)** It is made up of many organ systems that carry out the same function

Bala grew some green beans in a cup and placed it near the window. He watered the seedling daily. He then measured the height of the seedlings every four days. Which one of the following graphs best represents the height of the seedlings over 16 days?

A)

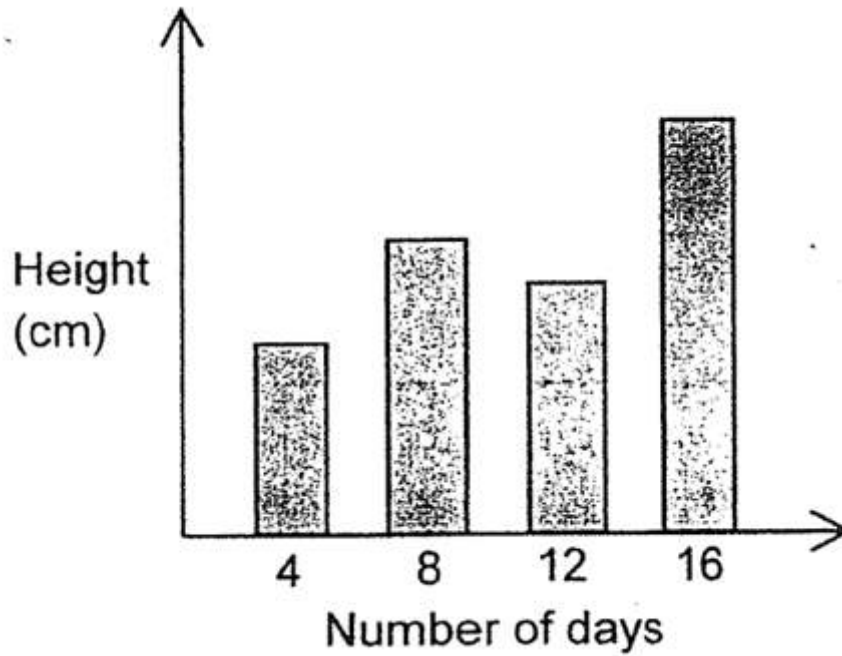

B)

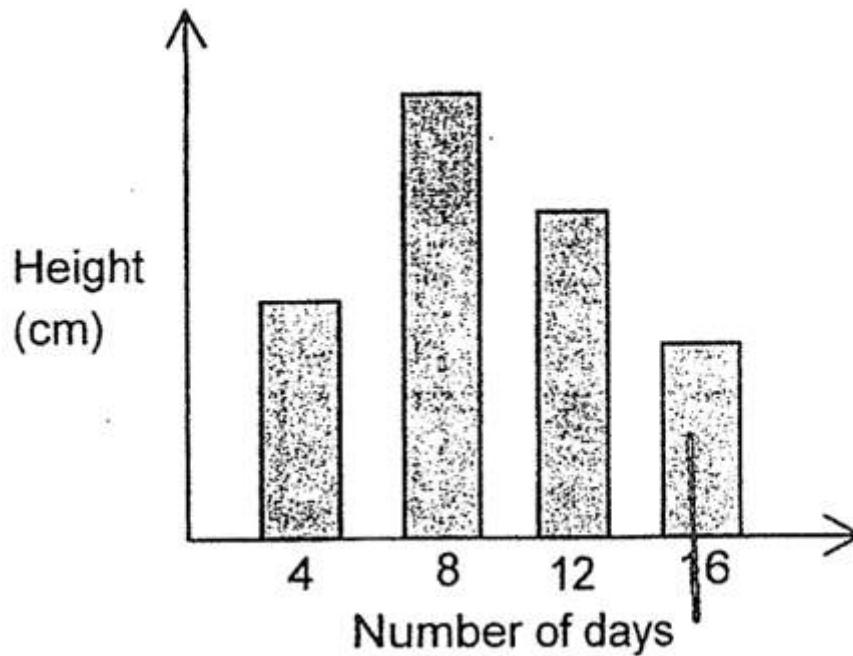

C)

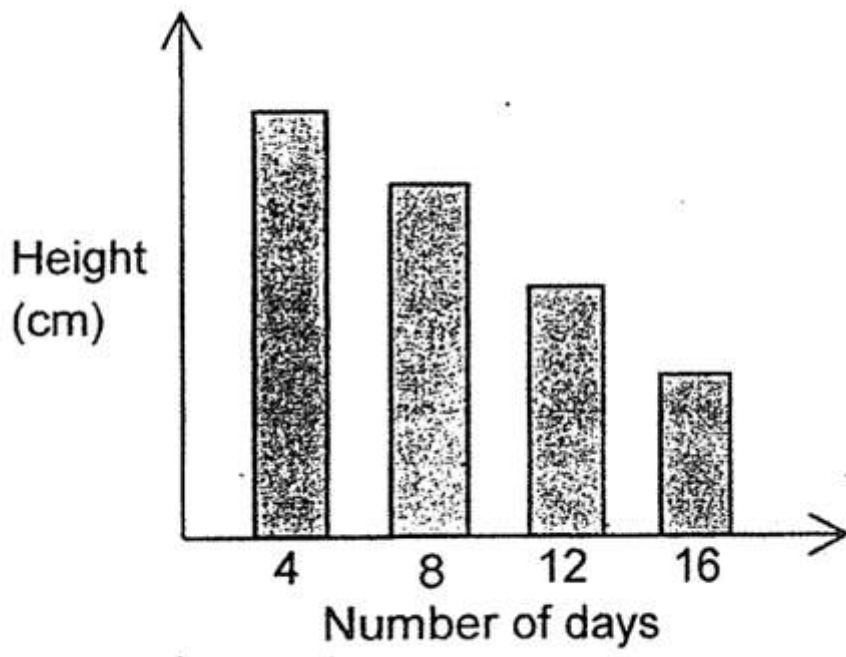

D)

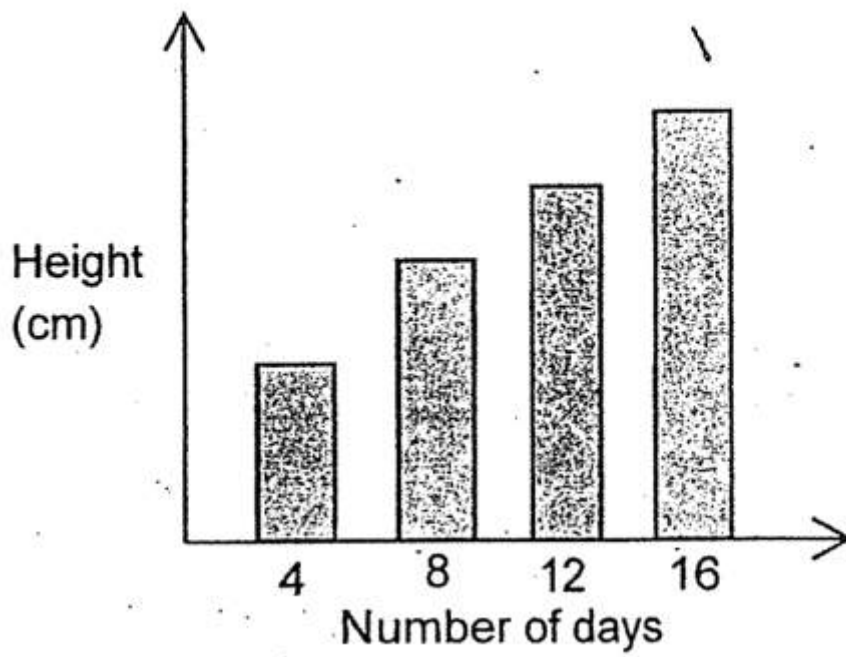

The diagram below represents the stages, A, B, C and D, of the life cycle of a special type of butterfly.

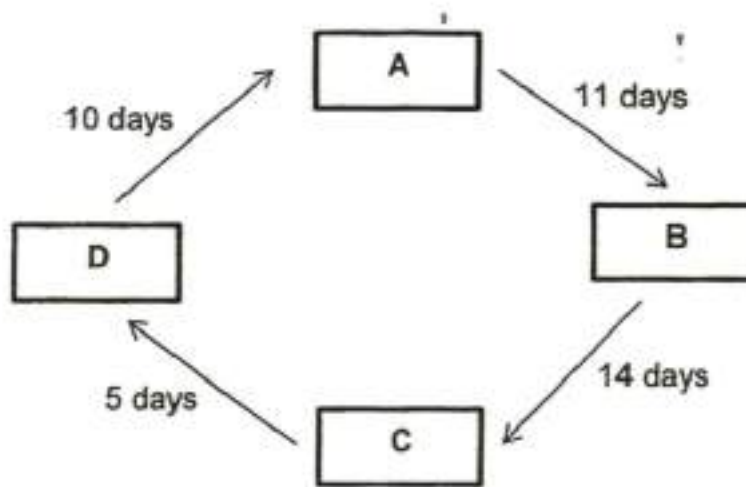

B represents the stage where the butterfly is able to reproduce.

At which stage would there be a lot of eating and shedding of skin to grow bigger?

-
- A) A
 - B) B
 - C) C
 - D) D

Alexander set up an experiment on the germination of a seedling.

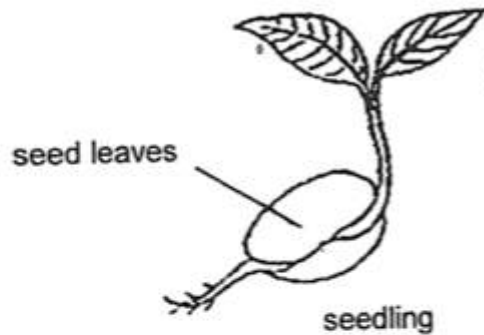

He measured the mass of the seed leaves and seedling and the results are shown in the graph below. One showed the change in the mass of the seed leaves while the other showed the change in the mass of the seedling.

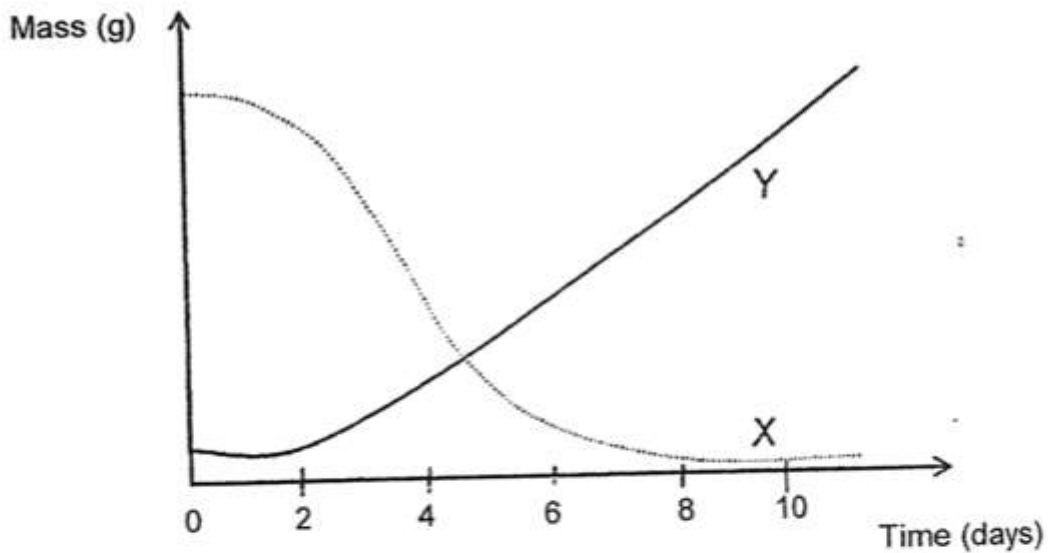

Which of the following statements describe the correct explanation for line X or Y?

| | Line | Reason |
|-----|------|---|
| (1) | X | The seedling makes its own food. |
| (2) | X | The seedling obtains its food from the seed leaves. |
| (3) | Y | The seed leaves makes its own food. |
| (4) | Y | The seed leaves obtains its food from the seedling. |

- A) 1
- B) 2
- C) 3
- D) 4

Johan prepared four set-ups P, Q, R and S, as shown in the table below.

| Set-up | P | Q | R | S |
|--|--------|---------|--------|--------|
| Variables | | | | |
| Number of green bean seeds | 5 | 5 | 10 | 5 |
| Amount of water added to the seeds everyday (cm ³) | 100 | 100 | 100 | 0 |
| Location where the set-up is placed | garden | freezer | garden | garden |

Johan selected the following set-ups for each of the following experiment.

Which one of the following set-ups and aims of the experiment is matched correctly?

| | Set-up | Aim of Experiment |
|-----|---------|--|
| (1) | P and Q | To find out if light is needed for germination |
| (2) | Q and R | To find out if the number of seeds affects germination |
| (3) | P and S | To find out if water is needed for germination |
| (4) | R and S | To find out if water is needed for germination |

-
- A) 1
 B) 2
 C) 3
 D) 4

Farah set up an experiment as shown below to investigate a property of three strips, K, L and M, which were made of different materials.

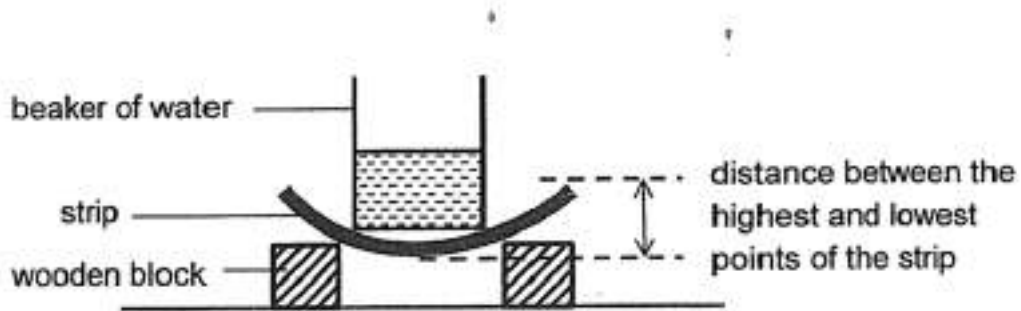

She placed the beaker on each strip. She then added different amounts of water into the beaker until the distance between the highest and lowest points of the strip reached 2 cm.

She recorded her results in the table below.

| Amount of Water in Beaker (ml) | | |
|--------------------------------|----|-----|
| K | L | M |
| 80 | 40 | 120 |

Based on the results, arrange the materials based on their flexibility, from the most flexible to the least flexible?

- A) M, K, L
 B) M, L, K
 C) K, L, M
 D) L, K, M

Aiman wanted to make a wall panel in his living room. The diagram below is the layout plan for his living room.

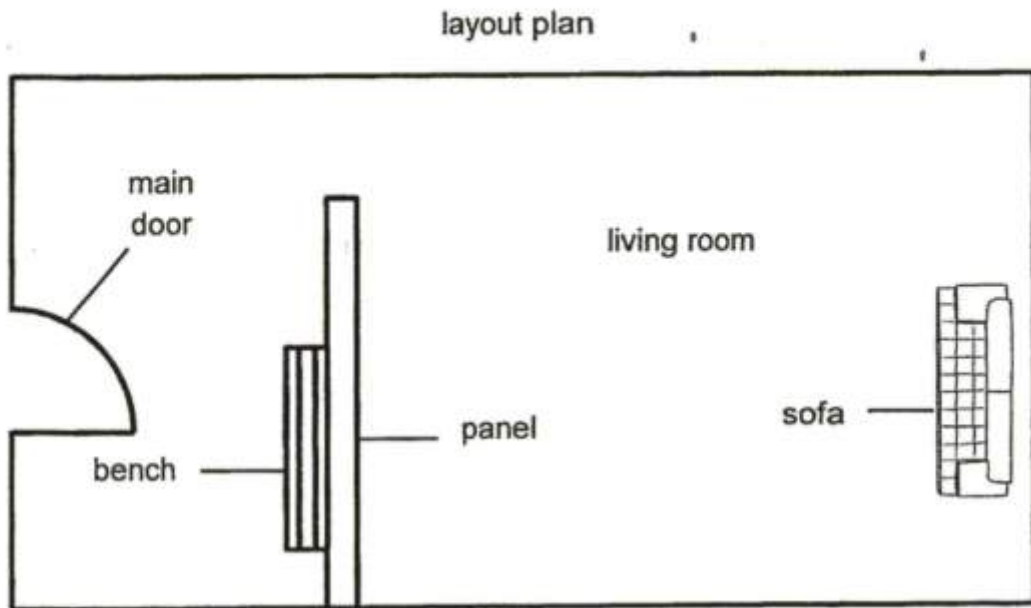

He told his contractor the following conditions:

- A: the sofa must not be seen clearly from the main door through the panel
- B: a person can lean on the panel while sitting on the bench

Based on the information given above, which of the following properties should the panel have?

| Properties of Materials to make the Wall Panel | | | | | |
|--|---------|--------|-----------------------------|---------------------------|-----------------------------|
| | Fragile | Strong | Most light can pass through | No light can pass through | Some light can pass through |
| (1) | ✓ | | | ✓ | |
| (2) | | ✓ | | | ✓ |
| (3) | | ✓ | ✓ | | |
| (4) | ✓ | | | | ✓ |

- A) 1
- B) 2
- C) 3
- D) 4

Damian placed a metal container between a torch and a screen. There was a heart painted on one side of the container.



He turns the metal container at different angles to face the torch. Which of the following shadows would **not** be cast on the screen?

A)



B)



C)



D)



The diagram below shows a balance with two objects, A and B hung at both ends. Objects A and B balance each other.

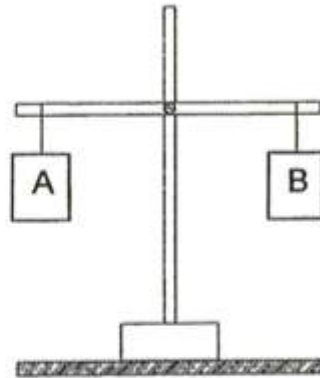

When object F is placed directly below object B, the balance tilted, as shown in the diagram below.

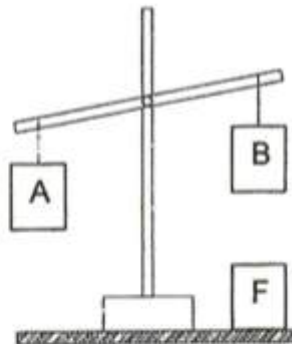

Based on the observations in both diagrams, what could be objects B and F?

| | Object B | Object F |
|-----|-------------|-------------|
| (1) | magnet | magnet |
| (2) | magnet | steel block |
| (3) | glass block | steel block |
| (4) | glass block | magnet |

- A) 1
- B) 2
- C) 3
- D) 4

Andy connected two identical bottles using a glass tube which contained a drop of ink. He placed one bottle in basin X and the other bottle in basin Y as shown in the diagram below. Basins X and Y contain equal amounts of water at different temperatures.

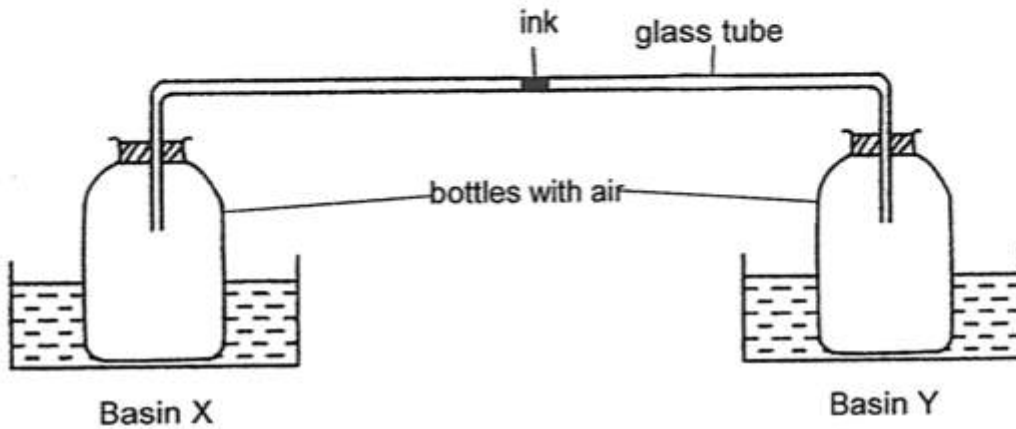

Which of the following shows the most likely result?

| | Temperature of water (°C) | | Direction of movement of ink |
|-----|---------------------------|---------|------------------------------|
| | Basin X | Basin Y | |
| (1) | 20 | 80 | → |
| (2) | 80 | 20 | → |
| (3) | 80 | 40 | ← |
| (4) | 40 | 20 | ← |

- A) 1
- B) 2
- C) 3
- D) 4

The diagram below shows a beaker filled with two substances, X and Y.

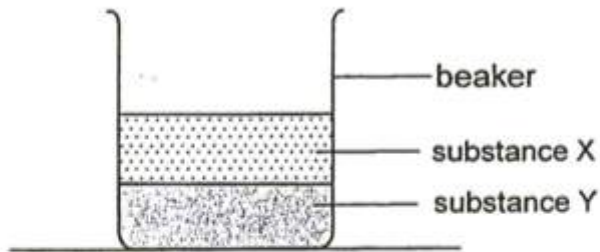

The beaker was then put on a ramp, as shown below.

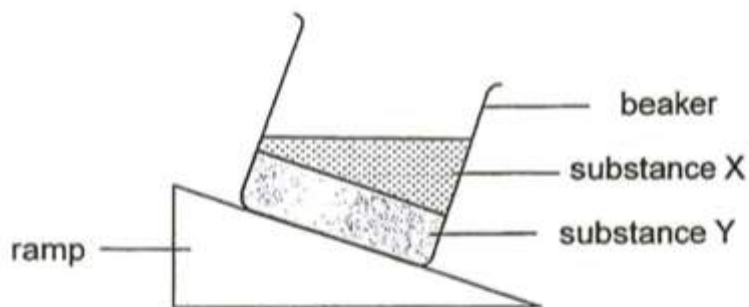

Which states of matter do you think substances X and Y are in?

| | X | Y |
|-----|--------|--------|
| (1) | liquid | solid |
| (2) | solid | liquid |
| (3) | gas | solid |
| (4) | gas | liquid |

- A) 1
- B) 2
- C) 3
- D) 4

Stephanie placed a wooden stick on the ground, as shown below. She measured the length of the shadow at 8am, 10 am, 2pm and 6pm.

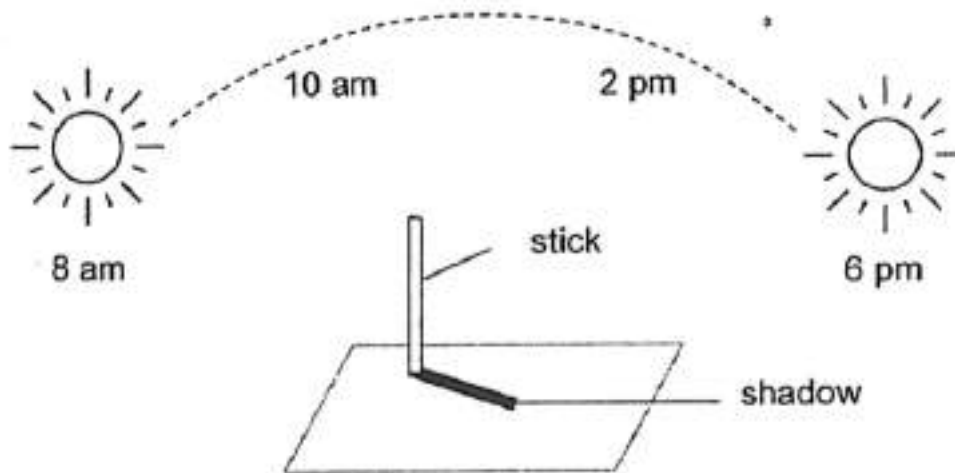

Which of the following graphs best represents the length of the shadow formed by the stick at different times of the day?

A) Length of shadow (cm)

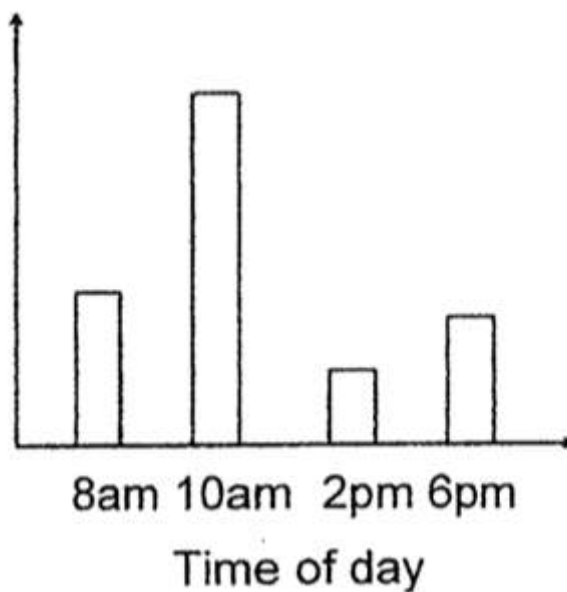

B)

Length of shadow (cm)

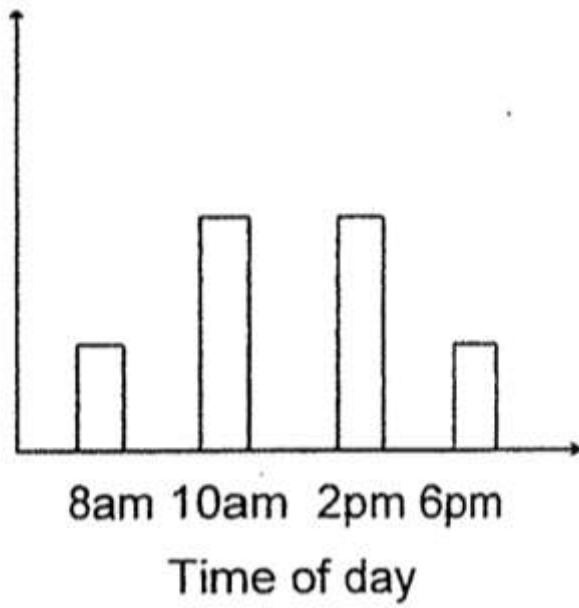

c)

Length of shadow (cm)

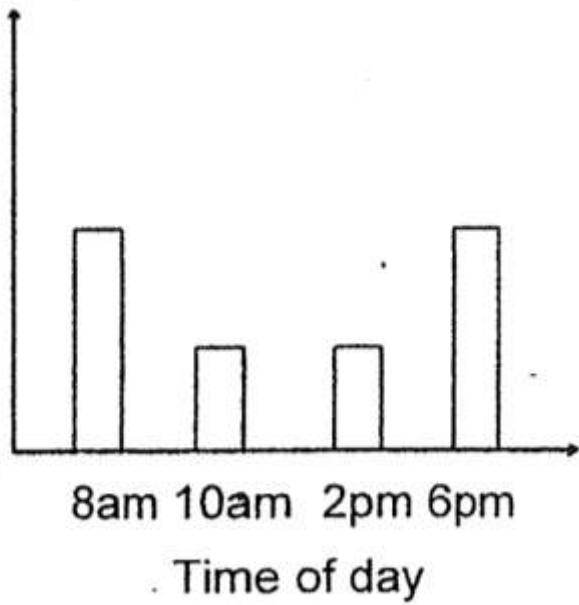

D)

Length of shadow (cm)

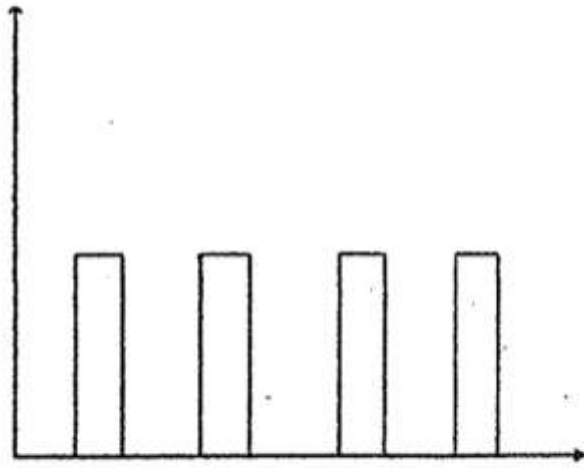

8am 10am 2pm 6pm

Time of day

Jessica carried out an experiment as shown below to find out how the distance between the light source and an object could affect the height of its shadow on a screen.

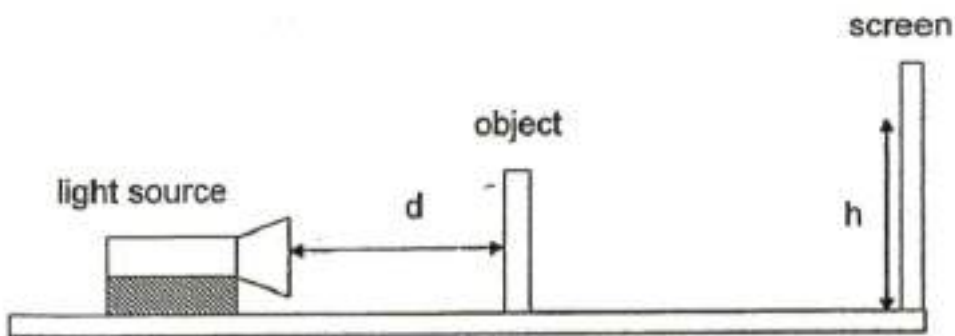

She recorded her results as shown in the table below.

| | | | | |
|---|----|----|----|----|
| Distance (d) between the light source and the object (cm) | 10 | 20 | 30 | 40 |
| Height (h) of the shadow cast on the screen (cm) | 35 | 21 | 16 | 10 |

Based on Jessica's experiment, the height of the shadow is

_____.

- A) shorter when the light source is nearer the object
- B) unchanged when the light source is nearer the object
- C) taller when the light source is further away from the object
- D) shorter when the light source is further away from the object

Mariah placed an ice cube each on two boards made of different material X and Y as shown below. Mariah wanted to find out which ice cube would take a longer time to melt completely.

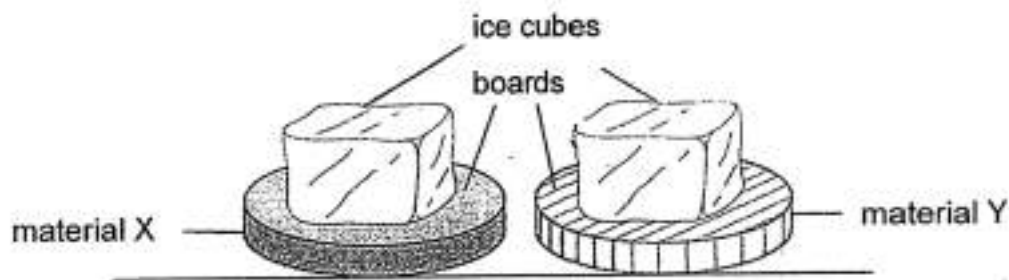

Which one of the following was changed for her investigation?

- A) The size of ice cubes
- B) The number of ice cubes
- C) The material of the boards
- D) The location of the set-ups

A bottle of cold milk was placed in a cup of hot water.

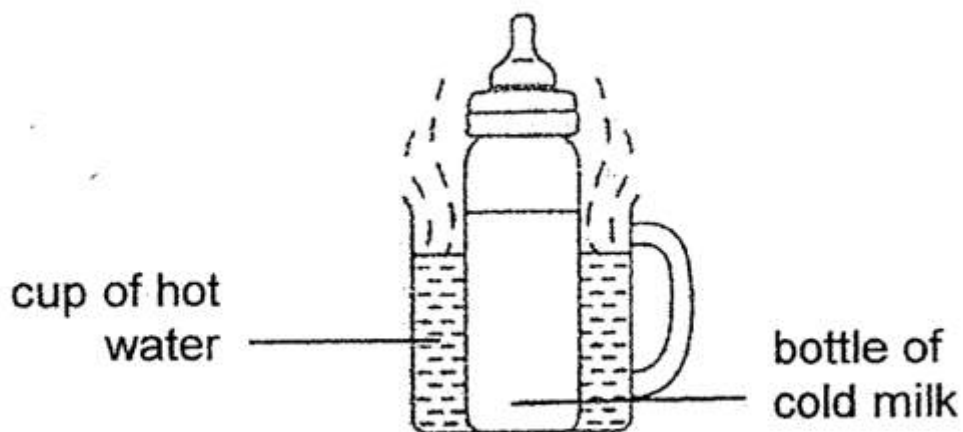

Which of the following statements is true?

- A) The cold milk loses heat to the hot water
- B) The temperature of the cold milk decreases
- C) The temperature of the hot water decreases
- D) The hot water gains heat from the surrounding

Walking pavements that we see on the street are often covered with concrete blocks with spaces as shown in the diagram below.

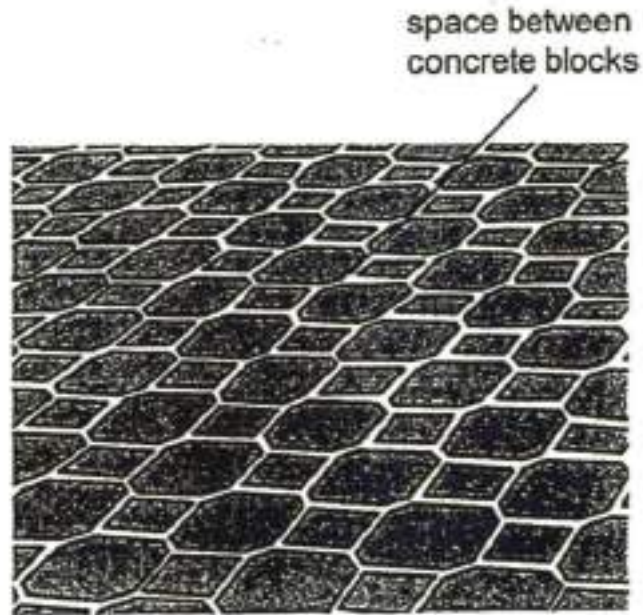

Which one of the following correctly explains why there are spaces between the concrete blocks?

-
- A) To allow the blocks to expand on hot days
 - B) To allow the blocks to contract on cold days
 - C) To allow dirt to be removed easily from the pavement
 - D) To allow plants to grow in the spaces between the blocks

Booklet B

This section is designed for extended answers that parent/ teacher will have to assign and guide child to attempt after the test has been completed.

Grading: This question type is not graded on this system and will not affect the final score as it was designed in such a way that it requires manual assistance.

Study the diagram below.



State the needs of the caterpillar to stay alive.

The caterpillar become bigger after some time. What is the characteristic of living things shown by the caterpillar?

The diagram below shows the human digestive system.

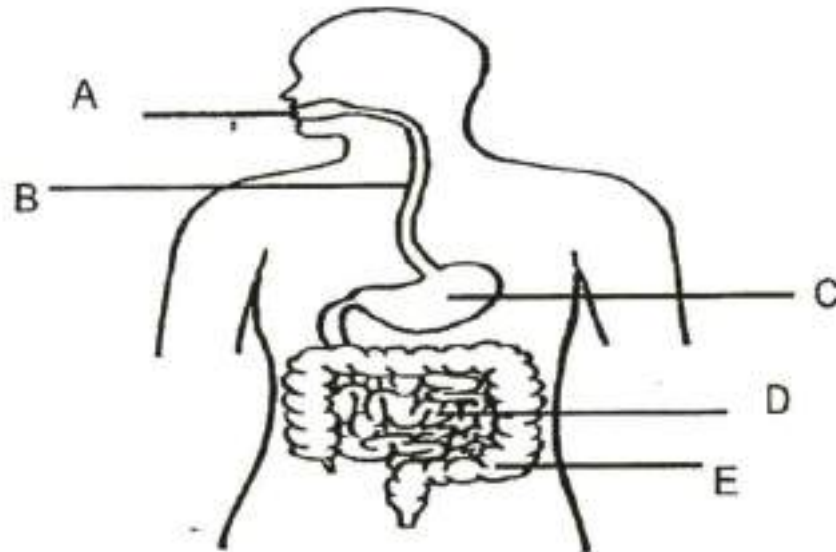

In which part (A, B, C, D or E) does digestion first takes place?

- A) A
- B) B
- C) C
- D) D
- E) E

In which part is most digested food absorbed into the bloodstream?

- A) A
- B) B
- C) C
- D) D
- E) E

The diagram below shows the stages in the life cycle of a cockroach.

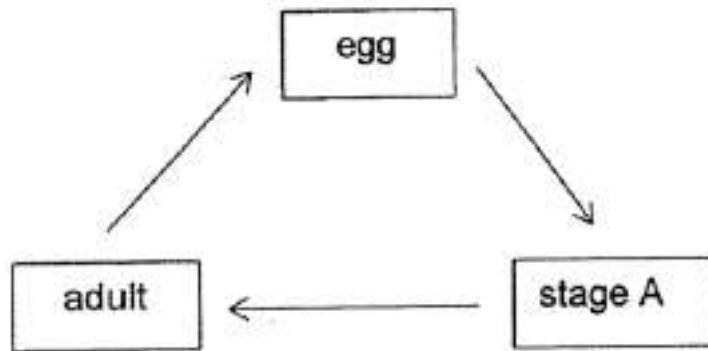

Name stage A.

stage A : _____

Which animal has a similar life cycle as the cockroach

- A) grasshopper
- B) butterfly
- C) mealworm beetle

The diagram below shows a magnifying glass.



Part X is made of glass because it allows _____ to pass through so that the person can see the magnified object.

Part Y is made of _____ because Y has to be strong.

Question 37 of 63

Primary 4 Science (Term 4)

3 pts

Match the options below:

1. []

Alex pours milk from a bottle onto a table as shown below.

A. liquid



The volume of the milk remains the same but its shape changes.

This shows that milk is a _____.

2. []

Alex pours some marbles from a bottle onto a table as shown below.

B. solid



The shape and volume of the marbles remain the same.

This shows that a marble is a _____.

3. []

The air in the bottle is a _____.

C. gas

Question 38 of 63

Primary 4 Science (Term 4)

1 pt

Which one of the followings can be compressed

- A) milk
- B) marble
- C) air

Cheryl took four slices of bread from the same loaf. She added different amount of water on the four slices of bread, A, B, C and D. She kept all the four slices of bread in a dark room. The results are as shown in the picture and table below.

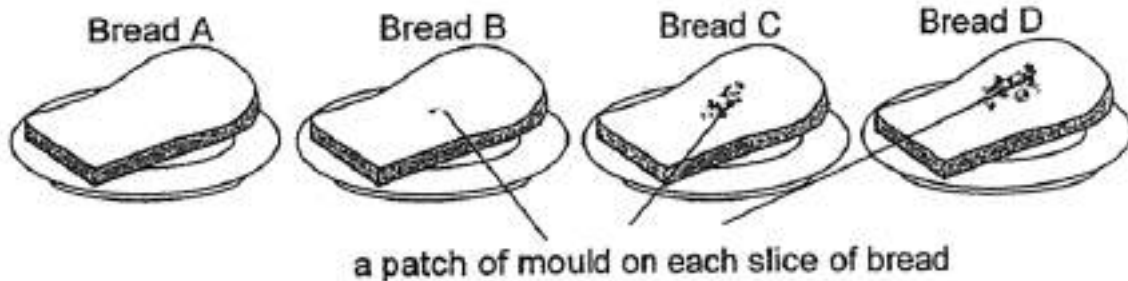

| Bread | Amount of Water (Number of Droplets) | Size of Each Patch of Mould (cm) |
|-------|---|-------------------------------------|
| A | 0 | 0 |
| B | 5 | 1 |
| C | 10 | 3 |
| D | 15 | 6 |

Based on the set-ups above, identify the condition that has affected the reproduction of the mould.

State the relationship between the amount of water and the size of each patch of mould.

Question 41 of 63

Primary 4 Science (Term 4) 0.5 pts

Choose the correct variables accordingly

Location:

- A) changed
- B) kept the same
- C) measured

Question 42 of 63

Primary 4 Science (Term 4) 0.5 pts

Type of bread:

- A) changed
- B) kept the same
- C) measured

Question 43 of 63

Primary 4 Science (Term 4) 0.5 pts

Amount of water: _____

- A) changed
- B) kept the same
- C) measured

Question 44 of 63

Primary 4 Science (Term 4) 0.5 pts

Size of each patch of mould:

- A) changed
- B) kept the same
- C) measured

Ali placed a plant in set-up X. He put a layer of oil over the water. He then measured the amount of water left in the beaker at the end of each day. After measuring the amount of water left on Day 10, Ali covered the roots of the plant completely using a plastic bag as shown below.

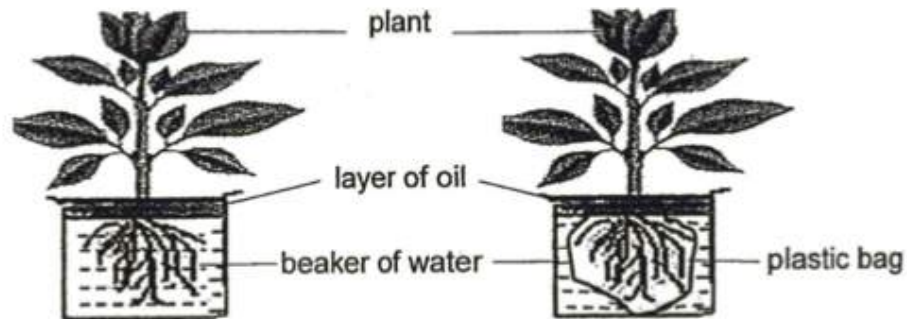

set-up X from Day 0 to Day 10

set-up X from Day 11 to Day 20

The graph below shows the result of his experiment.

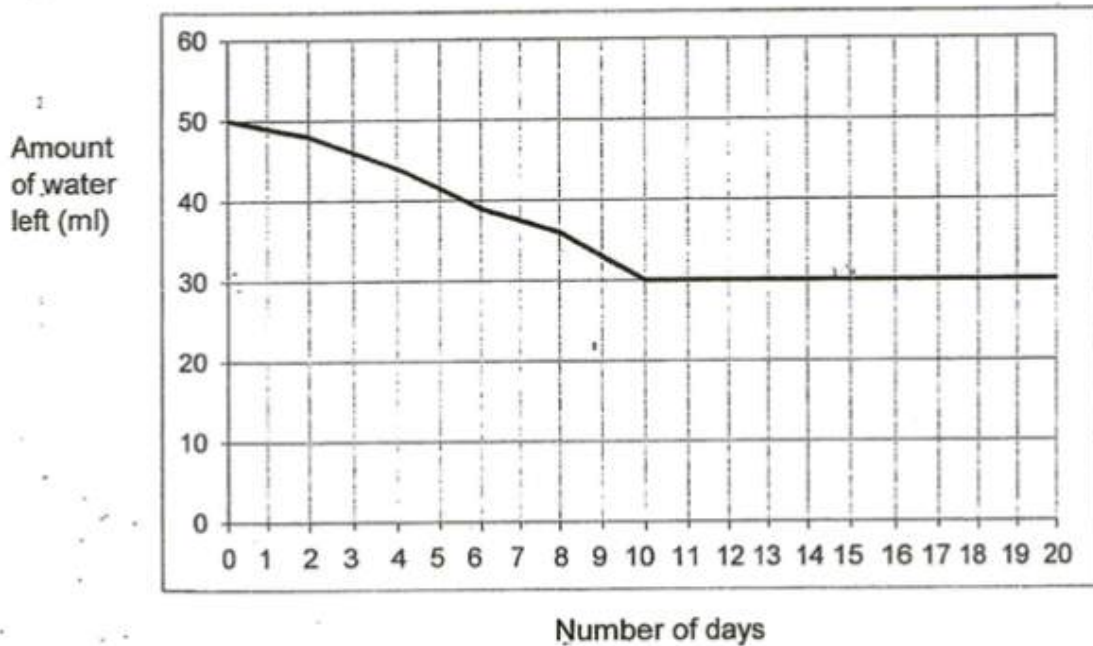

- (a) Based on the graph above, describe the changes in the amount of water left in the beaker from Day 1 to Day 20. [2]

Ali then carried out another experiment after Day 20. He covered up the roots of another similar plant using a paper bag in set-up Y. He compared set-ups X and Y for some time as shown below.

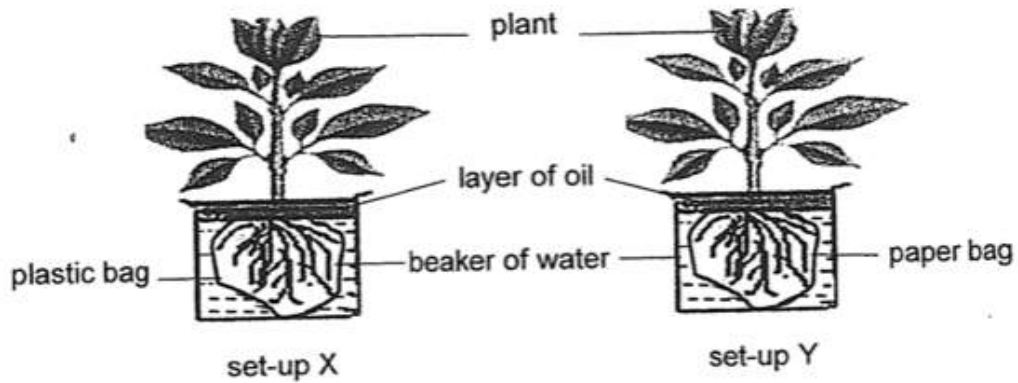

- (b) In which set up, X or Y, will the plant survive longer? Give a reason for your choice. [2]

Bill wanted to study the growth of a mealworm. He placed a mealworm in a box covered with a plastic cover as shown below.

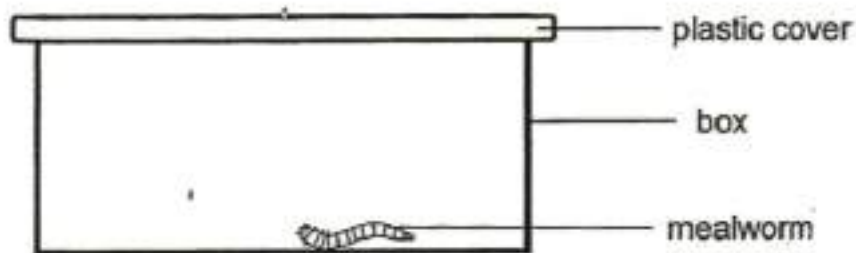

State two things that Bill should do to improve his set-up. [2]

Question 48 of 63

Primary 4 Science (Term 4)

0 pts

His friend told him that he should release the mealworm once it has grown into an adult.
Why was it important to release the mealworm beetle?

Choose the sources of light

A)



mirror



B)



fire



C)



eyes

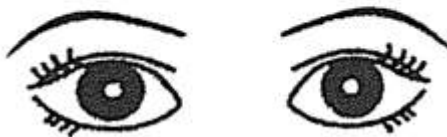

D)

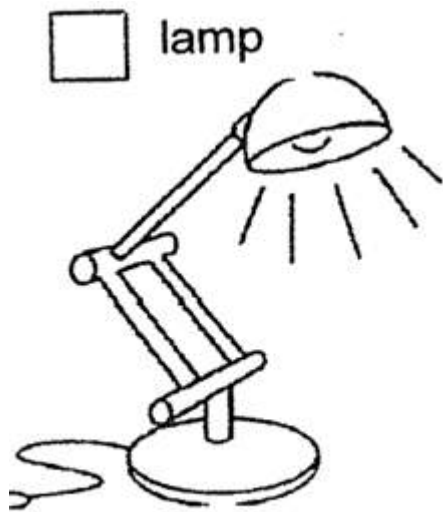

Question 50 of 63

Primary 4 Science (Term 4)

1 pt

Mr Ong walked towards a street lamp at night.
At which position should Mr Ong stand for his shadow to be the shortest?
Tick the correct box below. [1]

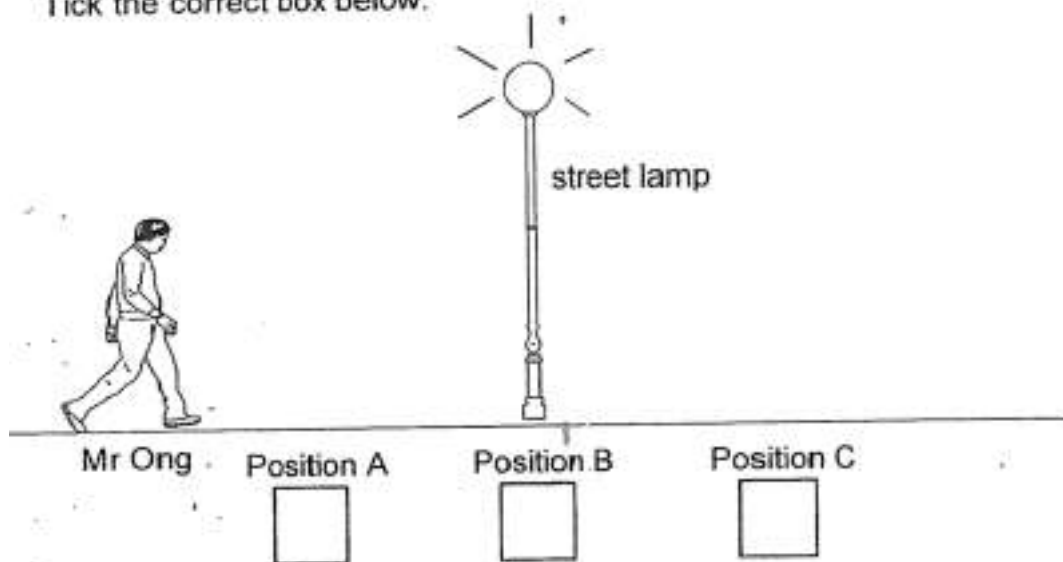

- A) position A
- B) position B
- C) position C

Question 51 of 63

Primary 4 Science (Term 4)

0 pts

Explain how Mr Ong's shadow was formed.

Janice used an instrument to measure the temperature of water in a tank.

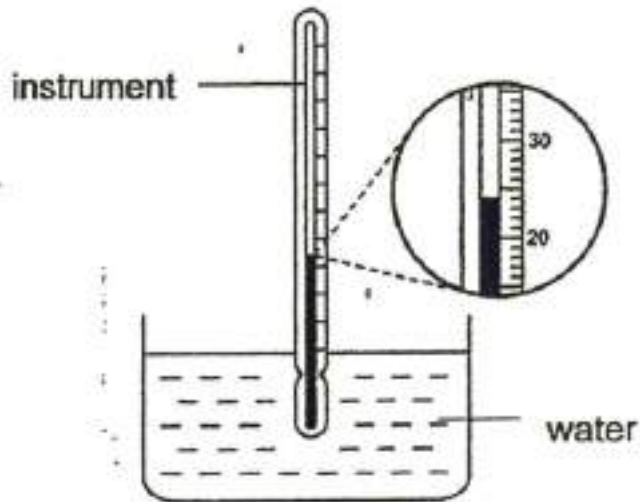

What is the name of the instrument?

What is the temperature of the water in the tank?

_____ °C

Janice heated the tank of water. She then placed a metal rod and a plastic rod into the tank as shown below. Equal amount of wax were placed on both rods.

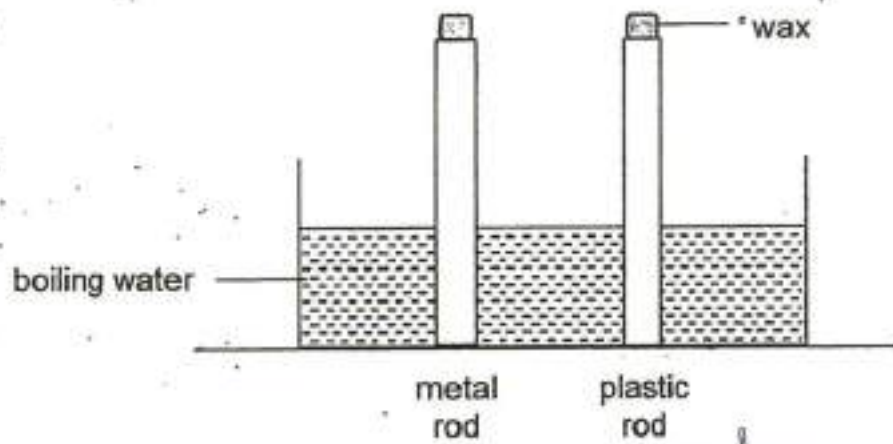

Which rod would cause the wax to melt faster? Explain your answer.

[2]

Match the options below:

Jacky set up an experiment as shown below. A pin was slowly pushed along the ruler towards magnet M. Jacky recorded the distance, d , at the point where the pin was attracted to the magnet. He repeated these steps with magnets N and O.

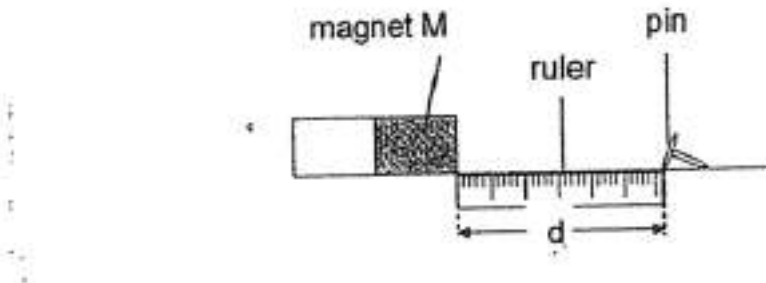

Jacky recorded his observations in the table below.

| Magnet | d (cm) |
|--------|----------|
| M | 4 |
| N | 9 |
| O | 5 |

Based on the results in the table, arrange the bar magnets (M, N and O) according to their strength from the weakest to the strongest. [1]

1. [] Weakest

A. M

2. [] Medium

B. O

3. [] Strongest

C. N

What is a possible material that the pin can be made of?

Question 57 of 63

Primary 4 Science (Term 4)

1 pt

Jacky then hammered the bar magnet M 40 times repeatedly. He then conducted the same experiment by pushing the pin slowly along the ruler towards the bar magnet M.

Will the distance d be shorter, longer or the same as 4cm?

- A) shorter
- B) longer
- C) same as 4cm

Question 58 of 63

Primary 4 Science (Term 4)

0 pts



Explain why.

Rosalind wanted to find out the amount of light which can pass through two different materials X and Y.

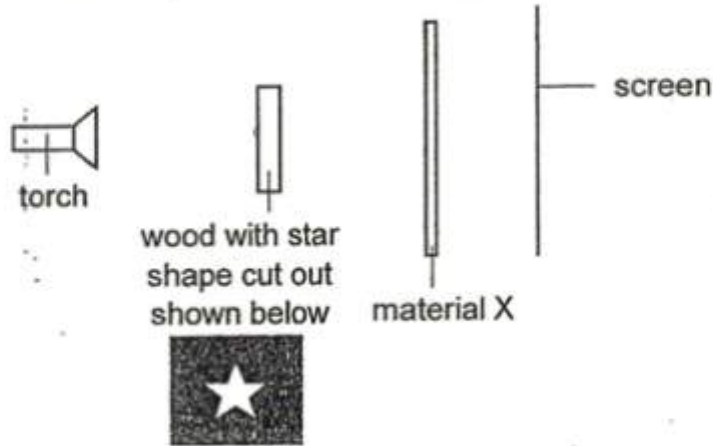
She set up her experiment as shown in the diagram below using material X and then repeated the experiment with material Y.



She also observed the brightness of the light patch seen on the screen.

| Materials used | Image on white screen |
|--------------------|--|
| No material placed |  Bright light patch seen |
| X |  No light patch seen |
| Y |  Dim light patch seen |

What would Rosalind do to make the image bigger? Tick the correct box(es) below. [1]

- A) Move the torch further from the wood
- B) Move the wood nearer to the torch
- C) Move the wood to the screen

Question 60 of 63

Primary 4 Science (Term 4) 0 pts

Rosalind changed the torch to increase the brightness of the light. What would happen to the image formed using material Y?

Question 61 of 63

Primary 4 Science (Term 4) 0 pts

Rosalind wanted to wrap a bottle with a material so that the liquid inside cannot be seen. Which of the material, X or Y, should she use? Give a reason for your choice.

Question 62 of 63

Primary 4 Science (Term 4) 0 pts

1. Ayden put a toy soldier in his submarine with clear sides. There were two holes A and B on the submarine. When he pushed the submarine into a tank of water, the toy soldier floated upwards and bubbles were seen coming out from hole A.

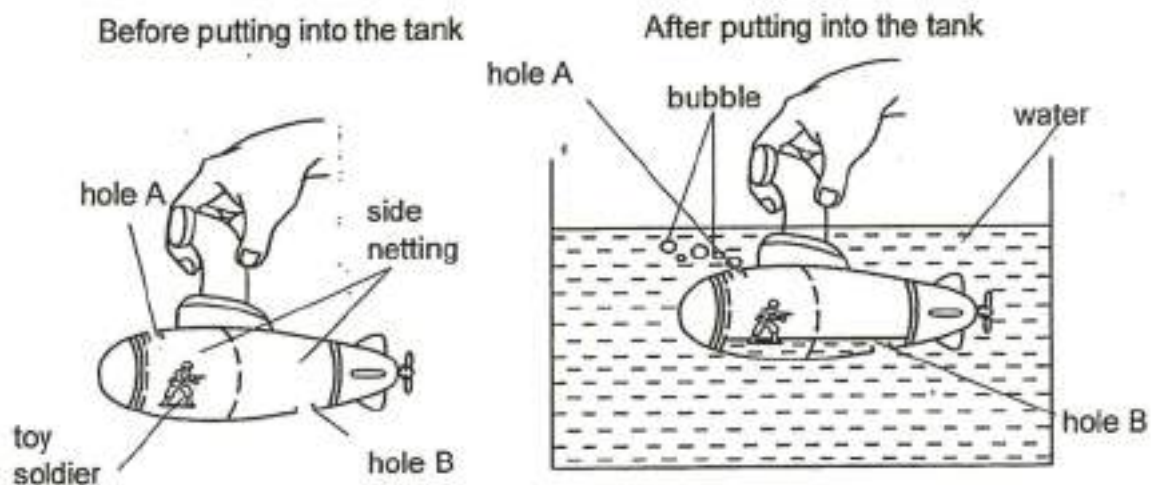

-) Explain why bubbles could be seen coming out from hole A when the submarine was pushed into the water.

[2]

When the submarine was pushed deeper into the water, the toy soldier rose and blocked hole A completely. Ayden observed that the water level in the submarine stopped rising.

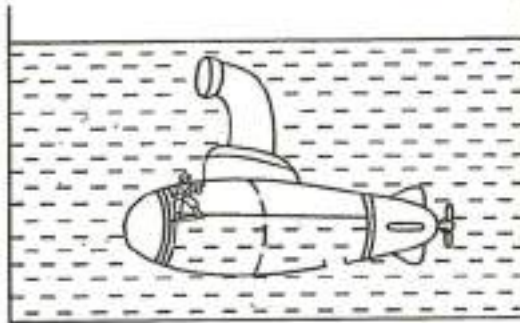

(b) Give an explanation for Ayden's observation

[2]